

BRCSS006N04SSL

Rev.C Jan.-2026

描述 / Descriptions

LFPAK5×6 封装 N 沟道场效应管。

N-Channel MOSFET in a LFPAK5×6 Plastic Package.

特征 / Features

$V_{DS} (V) = 40V$ $I_D = 300A$

$R_{DS(ON)}@10V \leq 0.68m\Omega$ (Typ. 0.57m Ω)

$R_{DS(ON)}@4.5V \leq 1.39m\Omega$ (Typ. 1.07m Ω)

无卤产品。HF Product.

用途 / Applications

电机驱动器，DC-DC 转换器。

Motor drivers, DC - DC Converter.

内部等效电路 / Equivalent Circuit

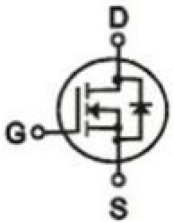

引脚排列 / Pinning

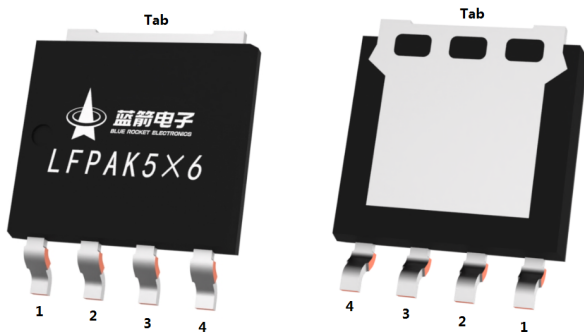

PIN1、2、3: S PIN4: G Tab: D

印章代码 / Marking

见印章说明。

See Marking Instructions.

极限参数 / Absolute Maximum Ratings(Ta=25°C)

参数 Parameter	符号 Symbol	数值 Rating	单位 Unit
Drain-Source Voltage	V_{DS}	40	V
Drain Current ^{①③}	$I_D(T_C=25^\circ C)$	300	A
	$I_D(T_C=100^\circ C)$	281	A
Pulsed Drain Current ^{①②}	I_{DM}	1200	A
Gate-Source Voltage	V_{GS}	± 20	V
Single Pulsed Avalanche Energy $L=1.0mH$ ^①	E_{AS}	800	mJ
Continuous-Source Current	I_S	300	A
Total Power Dissipation ^①	$P_D(T_C=25^\circ C)$	250	W
Junction and Storage Temperature Range	T_J, T_{STG}	-55 to 175	°C
Thermal Resistance-Junction to Ambient ^①	$R_{\theta JA}$	60	°C/W
Thermal Resistance-Junction to Case ^①	$R_{\theta JC}$	0.6	

Notes:

- ① Surface Mounted on 1 in² pad area, $t \leq 10$ sec
 ② Pulse width $\leq 300 \mu s$, duty cycle $\leq 2\%$
 ③ Limited by bonding wire

电性能参数 / Electrical Characteristics(Ta=25°C)

参数 Parameter	符号 Symbol	测试条件 Test Conditions	最小值 Min	典型值 Typ	最大值 Max	单位 Unit
Drain-Source Breakdown Voltage	BV_{DSS}	$V_{GS}=0V$ $I_D=250\mu A$	40			V
Zero Gate Voltage Drain Current	I_{DSS}	$V_{DS}=32V$ $V_{GS}=0V$			1	μA
Gate-Body Leakage Current Forward	I_{GSS}	$V_{GS}=\pm 20V$ $V_{DS}=0V$			± 100	nA
Gate Threshold Voltage	$V_{GS(th)}$	$V_{DS}=V_{GS}$ $I_D=250\mu A$	1		2.5	V
Static Drain-Source On-Resistance ^①	$R_{DS(on)}$	$V_{GS}=10V$ $I_D=30A$		0.57	0.68	m Ω
	$R_{DS(on)}$	$V_{GS}=4.5V$ $I_D=20A$		1.07	1.39	m Ω
Drain-Source Diode Forward Voltage ^①	V_{SD}	$V_{GS}=0V$ $I_S=30A$			1.3	V
Reverse Recovery Time	t_{rr}	$I_{DS} = 30 A, V_{GS} = 0 V$ $dI_{SD}/dt = 100 A/\mu s$		71		nS
Reverse Recovery Charge	Q_{rr}			77		nC
Input Capacitance	C_{iss}	$V_{DS}=20V$ $V_{GS}=0V$ $f=1.0MHz$		5733		pF
Output Capacitance	C_{oss}			2609		
Reverse Transfer Capacitance	C_{rss}			154		

电性能参数 / Electrical Characteristics(Ta=25°C)

参数 Parameter	符号 Symbol	测试条件 Test Conditions	最小值 Min	典型值 Typ	最大值 Max	单位 Unit
Total Gate Charge	Q_g	$V_{GS}=10V, V_{DS}=20V,$ $I_D=30A$		111		nC
Gate Source Charge	Q_{gs}			21		
Gate Drain Charge	Q_{gd}			27		
Turn-On Delay Time	$t_{d(on)}$	$V_{GEN}=10V V_{DS}=20V$ $R_L=0.66\Omega R_G=3.9\Omega$ $I_{DS}=30A$		18		ns
Turn-On Rise Time	t_r			73		
Turn-Off Delay Time	$t_{d(off)}$			102		
Turn-Off Fall Time	t_f			70		

电参数曲线图 / Electrical Characteristic Curve

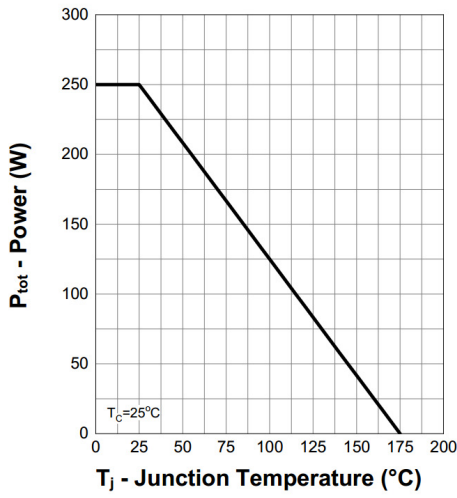

1. Power Capability

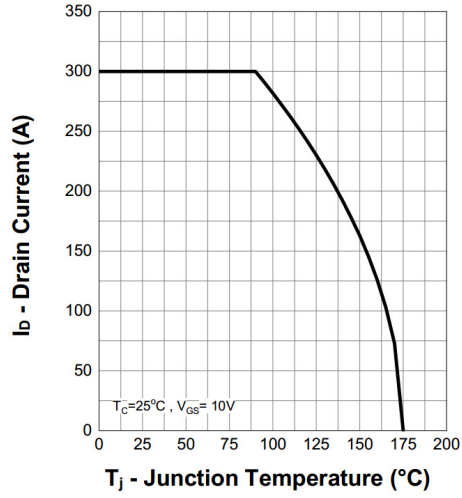

2. Current Capability

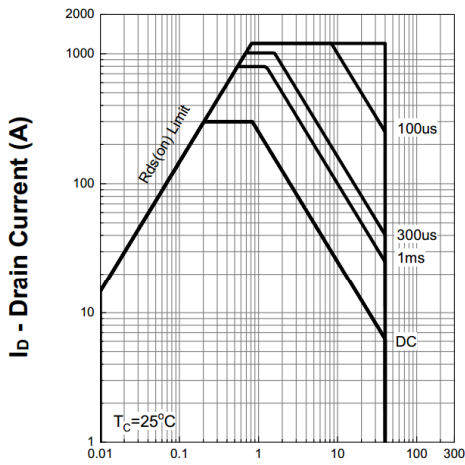

3. Safe Operating Area

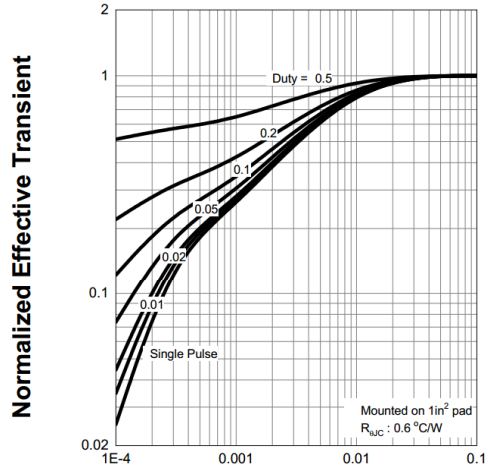

4. Transient Thermal Impedance

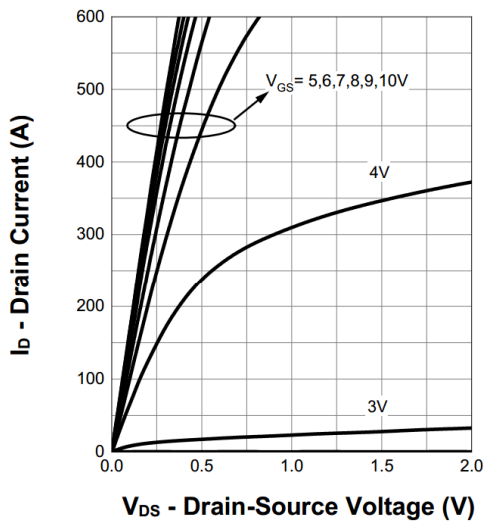

5. Output Characteristics

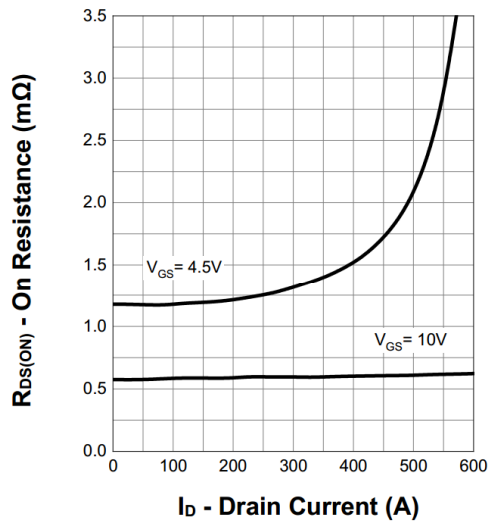

6. On Resistance

电参数曲线图 / Electrical Characteristic Curve

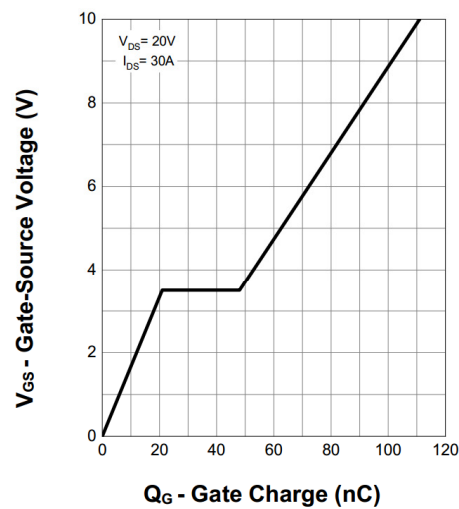
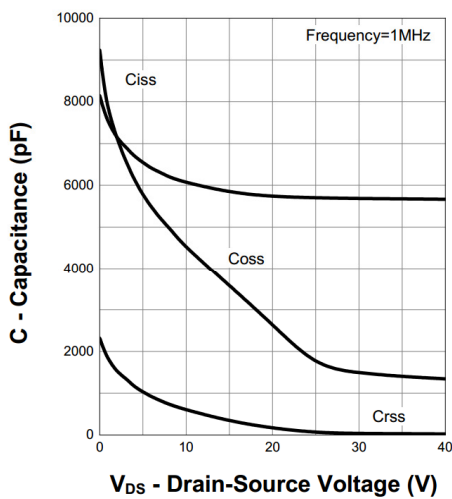
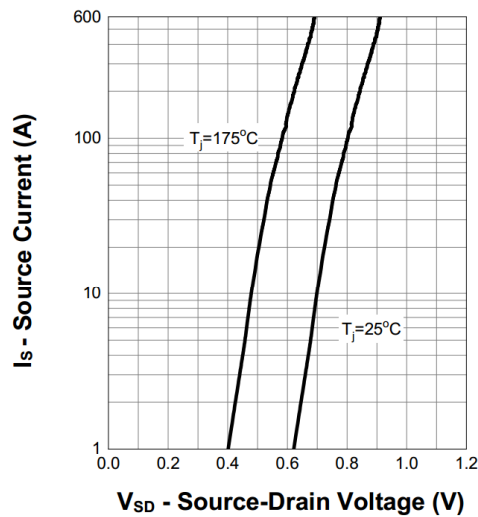
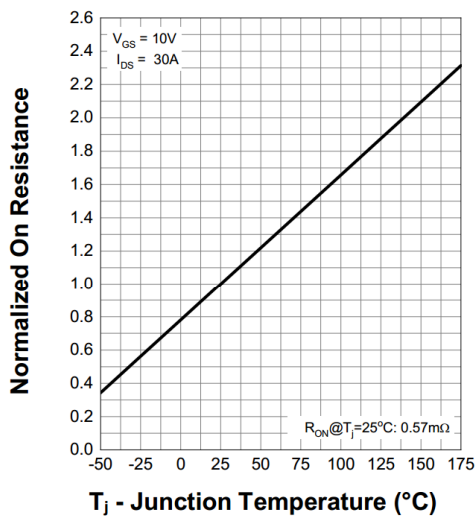
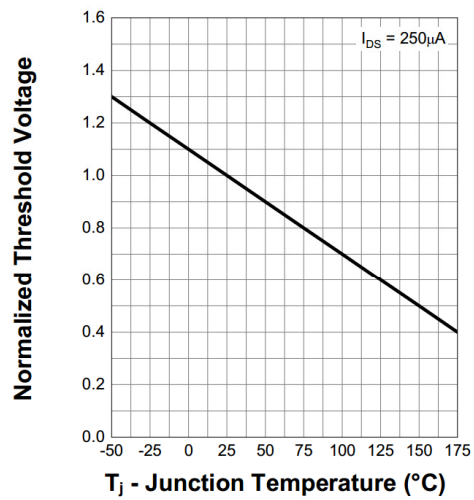
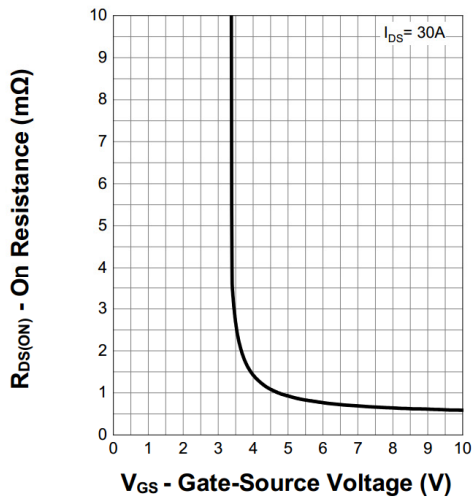

外形尺寸图 / Package Dimensions

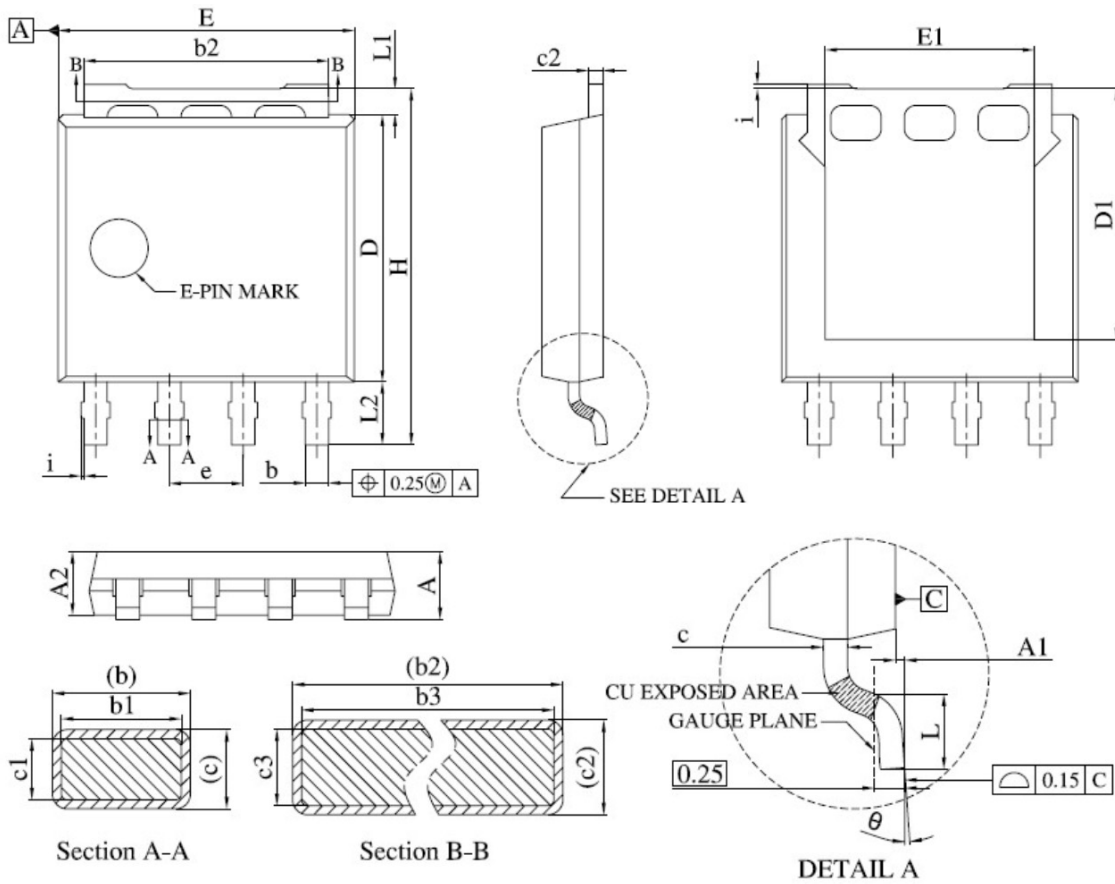

Symbol	Dimensions In Millimeters	
	MIN.	MAX.
A	1.00	1.30
A1	0.00	0.15
A2	0.98	1.12
b	0.35	0.50
b1	0.32	0.46
b2	4.02	4.41
b3	4.00	4.37
c	0.19	0.25
c1	0.17	0.23
c2	0.24	0.30
c3	0.22	0.28
D	4.45	4.70
D1	-	4.45

Symbol	Dimensions In Millimeters	
	MIN.	MAX.
E	4.95	5.30
E1	3.50	3.70
e	1.27 BSC.	
H	5.95	6.25
i	-	0.25
L	0.40	0.85
L1	0.27	0.57
L2	0.80	1.30
θ	0°	8°

印章说明 / Marking Instructions

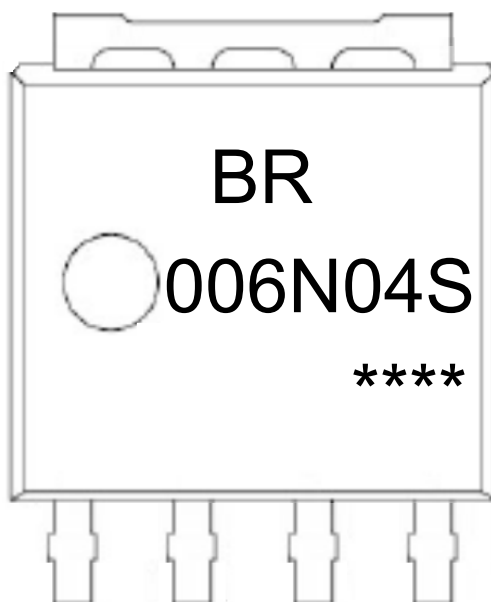

说明：

BR： 为公司代码

006N04S： 为型号代码

****： 为生产批号代码，随生产批号变化

Note：

BR: Company Code

006N04S: Product Type Code

****: Lot No. Code, code change with Lot No.

回流焊温度曲线图(无铅) / Temperature Profile for IR Reflow Soldering(Pb-Free)

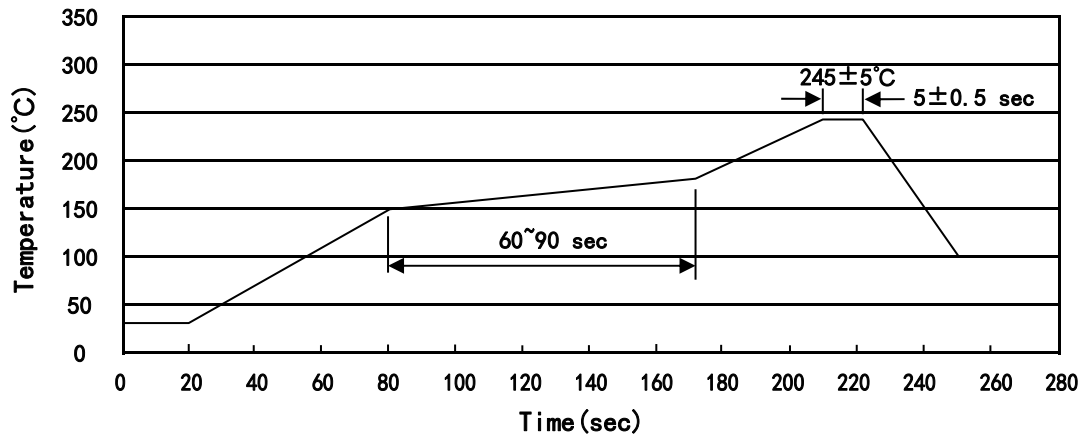

说明：

- 1、预热温度 150~180°C，时间 60~90sec;
- 2、峰值温度 245±5°C，时间持续为 5±0.5sec;
- 3、焊接制程冷却速度为 2~10°C/sec.

Note:

- 1.Preheating:150~180°C, Time:60~90sec.
- 2.Peak Temp.:245±5°C, Duration:5±0.5sec.
3. Cooling Speed: 2~10°C/sec.

耐焊接热试验条件 / Resistance to Soldering Heat Test Conditions

温度：260±5°C

时间：10±1 sec.

Temp.:260±5°C

Time:10±1 sec

包装规格 / Packaging SPEC.

卷盘包装 / REEL

Package Type 封装形式	Units 包装数量					Dimension 包装尺寸 (unit: mm ³)		
	Units/Reel 只/卷盘	Reels/Inner Box 卷盘/盒	Units/Inner Box 只/盒	Inner Boxes/Outer Box 盒/箱	Units/Outer Box 只/箱	Reel	Inner Box 盒	Outer Box 箱
LFPAK5×6	3,000	2	6,000	5	30,000	13"×12	356×335×50	385×285×358

Package Type 封装形式	Units 包装数量					Dimension 包装尺寸 (unit: mm ³)		
	Units/Reel 只/卷盘	Reels/Inner Box 卷盘/盒	Units/Inner Box 只/盒	Inner Boxes/Outer Box 盒/箱	Units/Outer Box 只/箱	Reel	Inner Box 盒	Outer Box 箱
LFPAK5×6	5,000	2	10,000	5	50,000	13"×12	356×335×50	385×285×358

使用说明 / Notices

本档中提供的所有信息均受法律免责声明的约束。

All information provided in this document is subject to legal disclaimers.