

描述 / Descriptions

The BRCD3508MF is a constant frequency, 6-pin SOT-23 current mode step-up converter intended for small, low power applications. The BRCD3508MF switches at 1.2MHz and allows the use of tiny, low cost capacitors and inductors 2mm or less in height. Internal soft-start results in small inrush current and extends battery life.

The BRCD3508MF features automatic shifting to pulse frequency modulation mode at light loads. The BRCD3508MF includes under-voltage lockout, current limiting, and thermal overload protection to prevent damage in the event of an output overload. The BRCD3508MF is available in a small 6-pin SOT-23 package.

特征 / Features

- ◆ Integrated 80mΩ Power MOSFET
- ◆ 2V to 24V Input Voltage
- ◆ 1.2MHz Fixed Switching Frequency
- ◆ Internal 4A Switch Current Limit
- ◆ Adjustable Output Voltage
- ◆ Internal Compensation
- ◆ Up to 28V Output Voltage Automatic Pulse Frequency Modulation
- ◆ Mode at Light Loads, Up to 97% Efficiency
- ◆ Available in a 6-Pin SOT23-6 Package.
- ◆ Halogen-free Product. 无卤产品。

用途 / Applications

- ◆ Battery-Powered Equipment
- ◆ Set-Top Boxed
- ◆ White LED Driver
- ◆ DSL and Cable Modems and Routers
- ◆ Networking cards powered from PCI or PCI express slots.

内部等效电路& 应用电路 / Equivalent Circuit or Application Circuit

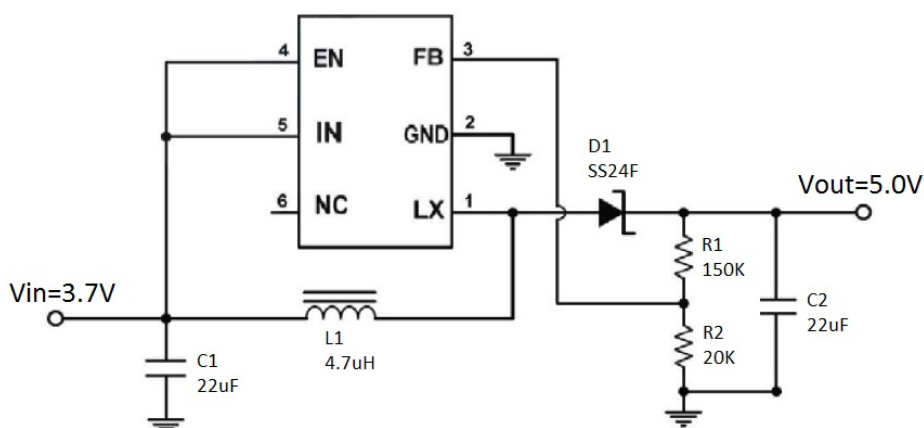

引脚排列 / Pinning

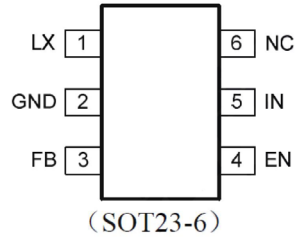

PIN	NAME	FUNCTION
1	LX	Power Switch Output. LX is the drain of the internal MOSFET switch. Connect the power inductor and output rectifier to LX. LX can swing between GND and 28V.
2	GND	Ground Pin
3	FB	Feedback Input. The FB voltage is 0.6V. Connect a resistor divider to FB.
4	EN	Regulator On/Off Control Input. A high input at EN turns on the converter, and a low input turns it off. When not used, connect EN to the input supply for automatic startup.
5	IN	Input Supply Pin. Must be locally bypassed.
6	NC	Not Connection

印章代码 / Marking

见印章说明。 See Marking Instructions.

极限参数 / Absolute Maximum Ratings(Ta=25°C)

参数 Parameter	符号 Symbol	数值 Rating			单位 Unit
		Min	Typ	Max	
Supply Voltage	Vcc	2.0		24	V
LX Voltage	VLX			28	V
EN,FB Voltage	V			24	V
Junction Temperature				155	°C
Operating Temperature		-40		85	°C
Lead Temperature				300	°C
Power Dissipation	PD			500	mW

电性能参数 / Electrical Characteristics(Ta=25°C)

参数 Parameter	测试条件 Test Conditions	最小值 Min	典型值 Typ	最大值 Max	单位 Unit
Operating Input Voltage		2.0		24	V
Under Voltage Lockout				1.98	V
Under Voltage Lockout Hysteresis			100		mV
Current (Shutdown)	VEN = 0V		0.1	1	μA
Quiescent Current (PFM)	VFB=0.7V, No switch		100	200	μA
Quiescent Current (PWM)	VFB=0.5V, switch		1.6	2.2	mA
Switching Frequency			1.2		MHz
Maximum Duty Cycle	VFB = 0V	90			%
EN Input High Voltage		1.5			V
EN Input Low Voltage				0.4	V
FB Voltage		0.588	0.6	0.612	V
FB Input Bias Current	VFB = 0.6V	-50	-10		nA
LX On Resistance ⁽¹⁾			80		mΩ
LX Current Limit ⁽¹⁾	VIN= 5V, Duty cycle=50%		3.5		A
LX Leakage	VLX = 20V			1.0	μA
Thermal Shutdown			155		°C

Note:

1) Guaranteed by design, not tested.

原理框图 / Functional Block Diagram

The BRCD3508MF uses a fixed frequency, peak current mode boost regulator architecture to regulate voltage at the feedback pin. The operation of the BRCD3508MF can be understood by referring to the block diagram of Figure1. At the start of each oscillator cycle the MOSFET is turned on through the control circuitry. To prevent sub-harmonic oscillations at duty cycles greater than 50 percent, a stabilizing ramp is added to the output of the current sense amplifier and the result is fed into the negative input of the PWM comparator. When this voltage equals the output voltage of the error amplifier the power MOSFET is turned off. The voltage at the output of the error amplifier is an amplified version of the difference between the 0.6V band gap reference voltage and the feedback voltage. In this way the peak current level keeps the output in regulation. If the feedback voltage starts to drop, the output of the error amplifier increases. These results in more current to flow through the power MOSFET, thus increasing the power delivered to the output. The BRCD3508MF has internal soft start to limit the amount of input current at startup and to also limit the amount of overshoot on the output.

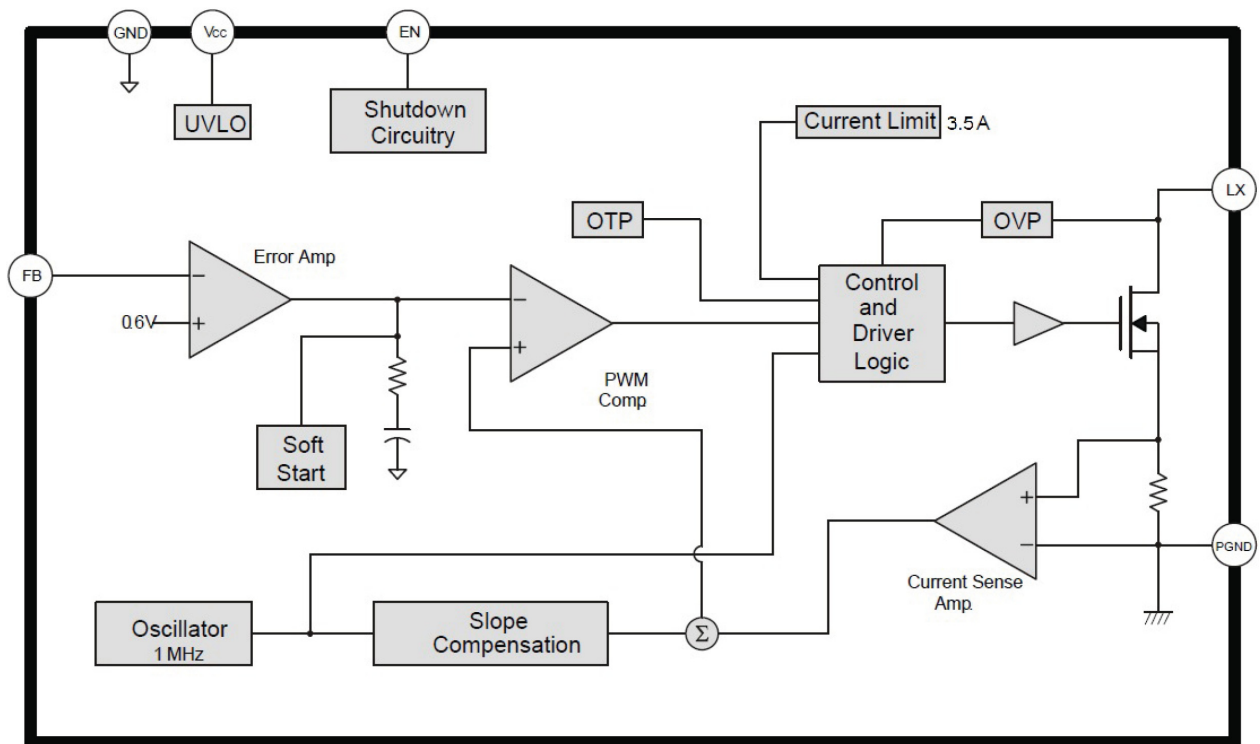

Figure 1:Functional Block Diagram

应用信息 / Application Information

Setting the Output Voltage

The internal reference VREF is 0.6V (Typical). The output voltage is divided by a resistor divider, R1 and R2 to the FB pin. The output voltage is given by:

$$V_{OUT} = V_{REF} \times \left(1 + \frac{R_1}{R_2}\right)$$

Inductor Selection

The recommended values of inductor are 4.7 to 22μH. Small size and better efficiency are the major concerns for portable device, such as BRCD3508MF used for mobile phone. The inductor should have low core loss at 1.2MHz and low DCR for better efficiency. To avoid inductor saturation current rating should be considered.

Capacitor Selection

Input and output ceramic capacitors of 22μF are recommended for BRCD3508MF applications. For better voltage filtering, ceramic capacitors with low ESR are recommended. X5R and X7R types are suitable because of their wider voltage and temperature ranges.

Diode Selection

Schottky diode is a good choice for BRCD3508MF because of its low forward voltage drop and fast reverse recovery. Using Schottky diode can get better efficiency. The high speed rectification is also a good characteristic of Schottky diode for high switching frequency. Current rating of the diode must meet the root mean square of the peak current and output average current multiplication as following :

$$I_D (RMS) \approx \sqrt{I_{OUT} \times I_{PEAK}}$$

The diode's reverse breakdown voltage should be larger than the output voltage.

Layout Consideration

For best performance of the BRCD3508MF, the following guidelines must be strictly followed.

- Input and Output capacitors should be placed close to the IC and connected to ground plane to reduce noise coupling.
- The GND should be connected to a strong ground plane for heat sinking and noise protection.
- Keep the main current traces as possible as short and wide.
- LX node of DC-DC converter is with high frequency voltage swing. It should be kept at a small area.
- Place the feedback components as close as possible to the IC and keep away from the noisy devices.

外形尺寸图 / Package Dimensions

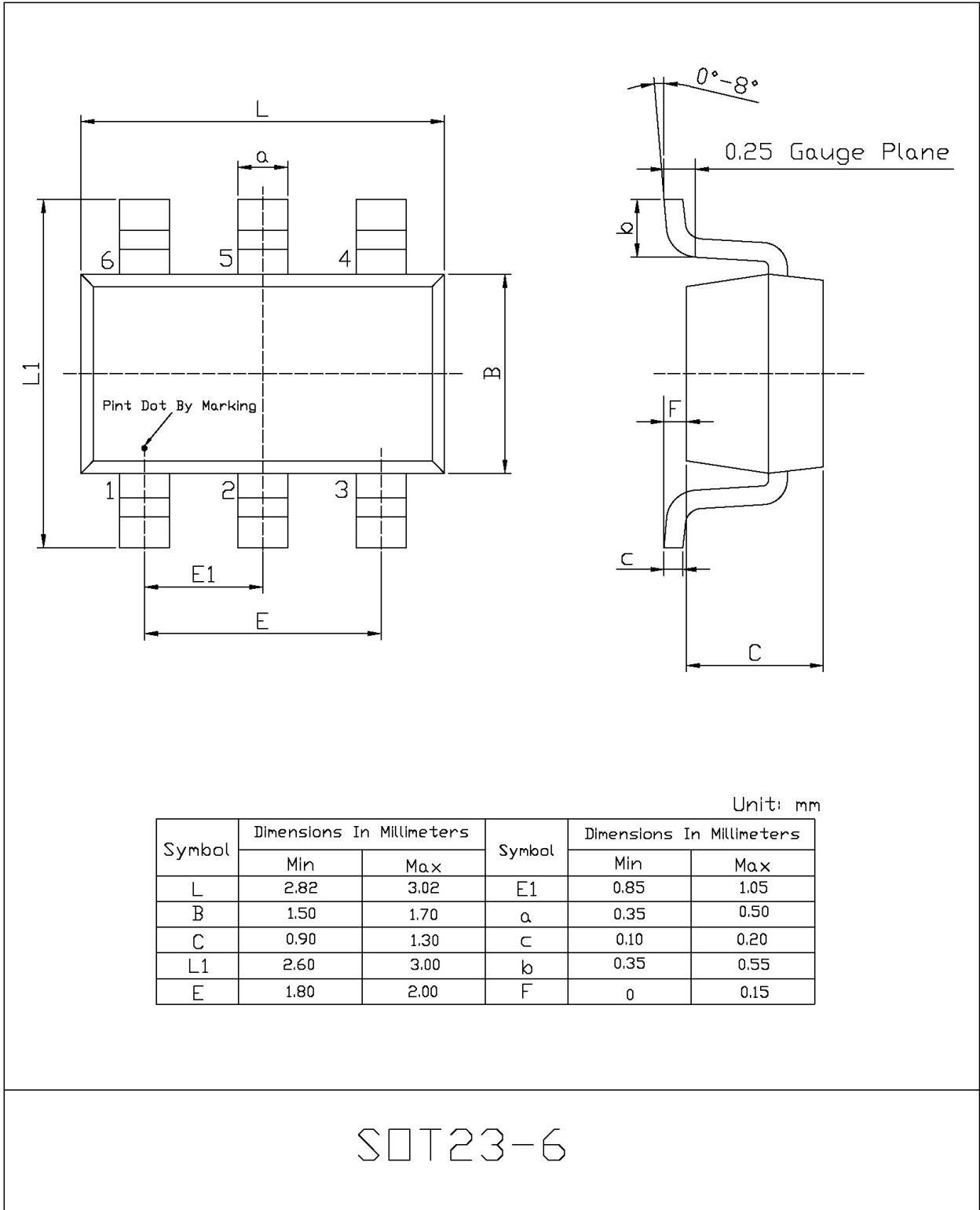

印章说明 / Marking Instructions

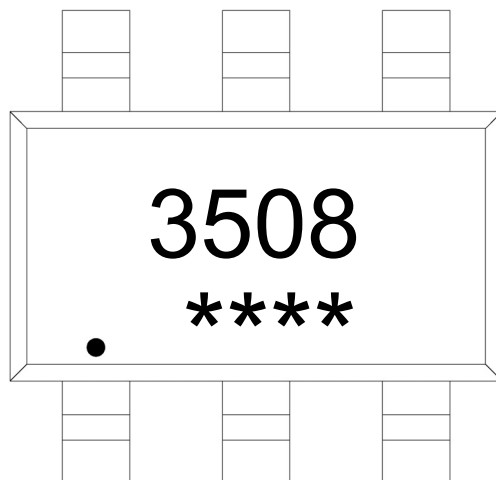

说明：

3508： 为产品型号

****： 为生产批号代码，随生产批号变化。

Note:

3508: Product Type.

****: Lot No. Code, code change with Lot No.

回流焊温度曲线图(无铅) / Temperature Profile for IR Reflow Soldering(Pb-Free)

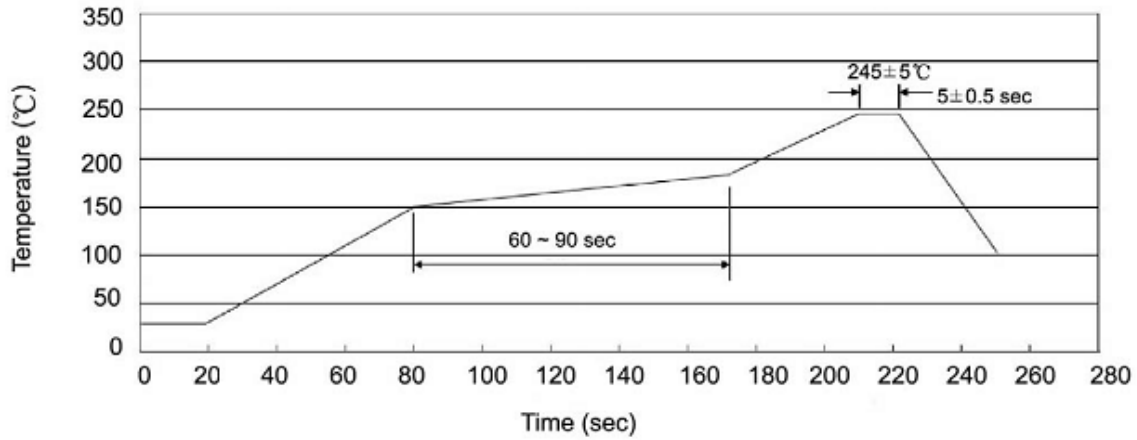

说明：

- 1、预热温度 150 ~ 180°C，时间 60 ~ 90sec;
- 2、峰值温度 245±5°C，时间持续为 5±0.5sec;
- 3、焊接制程冷却速度为 2 ~ 10°C/sec.

Note:

- 1.Preheating:150~180°C, Time:60~90sec.
- 2.Peak Temp.:245±5°C, Duration:5±0.5sec.
3. Cooling Speed: 2~10°C/sec.

耐焊接热试验条件 / Resistance to Soldering Heat Test Conditions

温度：260±5°C

时间：10±1 sec.

Temp.:260±5°C

Time:10±1 sec

包装规格 / Packaging SPEC.

卷盘包装 / REEL

Package Type 封装形式	Units 包装数量					Dimension 包装尺寸 (unit: mm ³)		
	Units/Reel 只/卷盘	Reels/Inner Box 卷盘/盒	Units/Inner Box 只/盒	Inner Boxes/Outer Box 盒/箱	Units/Outer Box 只/箱	Reel	Inner Box 盒	Outer Box 箱
SOT23-5/6	3,000	10	30,000	4	120,000	7" ×8	210×205×205	445×230×435

使用说明 / Notices